

FEATURES AND BENEFITS

Shut-off valve for gravity-flow pipe that drains into surge tank.

Submersible

Full boot seal for durable performance. No gaskets required

ANSI B16.5 Class 150 Flange Pattern. Face to face dimensions match Asahi Type 56/57 & Pool Pro™ BFV for direct retrofit.

Stainless Steel 2" Operating nut is retained by rails, which also stop rotation in the full-open or full-closed position, (with no locking positions between).

Designed to be operated with a 2" square valve key. (Colonial Part No V417681 or V417681S 2" Square Valve Key KIT is sold separately)

Because the valve in this configuration does not have locking throttling positions, the maximum recommended operating pressure at ambient temperature is 20 psi. This valve is designed to be used in the full-open or full-closed position on a drain pipe.



SAMPLE ENGINEERING SPECIFICATIONS

Surge (Butterfly) Shut-Off Valve body shall be produced of PVC Type I, cell classification 12454. Disc shall be produced of Polypropylene. Valve boot/seal and O-rings shall be made of EPDM. Stem shall be made of stainless steel. The disc bore (center) shall contain a integrally molded stainless steel reinforcement square liner, which engages with the stainless steel valve shaft. Flange bolt pattern shall conform to ANSI/ASME B 16.5 Class 150 standard. Stainless Steel 2" Operating nut will stop rotation in the full-open or full-closed position, mating with integral stem-stops. Colonial 411SV Series.



Revised 5/19/21- Size range is now 4 - 8"

PVC Body with PP Disc and EPDM seals.

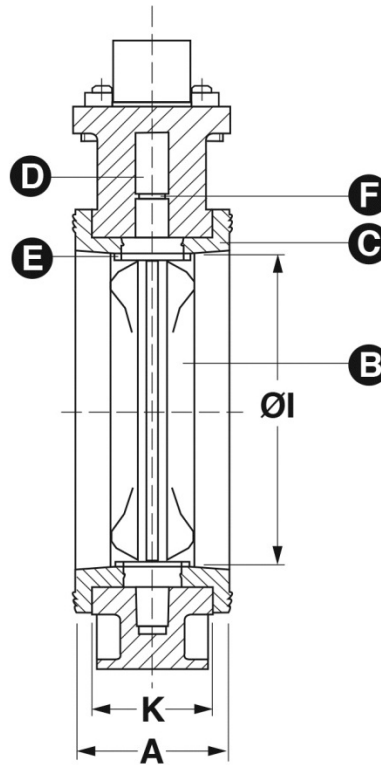
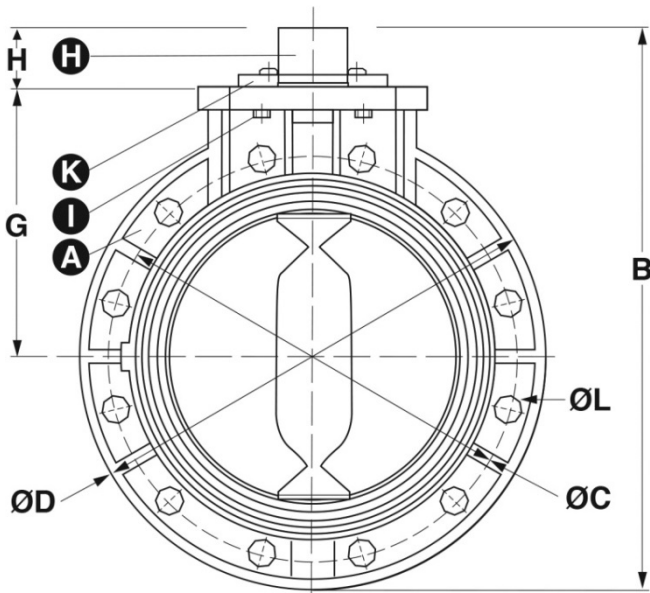

Part Letter	Component	Qty	Material
A	Body	1	PVC
B	Disc	1	PP
C	Seal	1	EPDM
D	Stem	1	410 SS
E	O-Ring	2	EPDM
F	Stem O-Ring	2	EPDM
H	Operating Nut	1	316 SS
I	Bolt & Washer	4	316 SS
K	Rail & Fasteners	2	PVC & 316 SS

Size	Part No	A	B	ØC	ØD	G	H	ØI	K	ØL*
4"	V40411SV	2 3/16"	12 3/4"	7 1/2"	9"	5 5/16"	2 3/16"	4 1/16"	1 7/8"	3/4"
6"	V60411SV	2-3/4"	14-3/4"	9-1/2"	11-1/4"	7	2 3/16"	6	2-7/16"	7/8"
8"	V80411SV	3-6/16"	17 1/4"	11-23/32"	13-1/2"	8-9/32"	2 3/16"	7-7/8"	3-1/16"	7/8"

*Flange bolt hole diameter: 4 -8" = 8 flange bolt holes;

2" Square Valve Key Kit - Carbon Steel. (Note: requires welding at jobsite) Includes steel handle with 44" stem, and separate 2" head for welding at the jobsite. Customer can weld additional 1" Sch 40 steel pipe (not included) as needed for the required length. Note: Customer must follow American Welding Society (AWS) Standards AWS D10.12, AWS D1.1, and any other applicable codes in relation to the welding process. **Part No: V417681 (Carbon Steel, V417681S 304 Stainless Steel)**

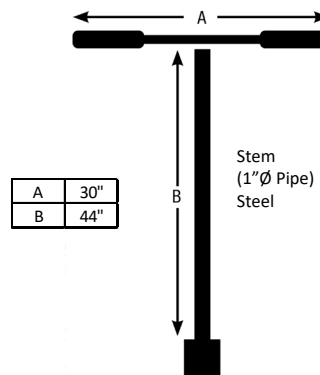

2" Square Head (separate from stem for welding at jobsite). Weld additional 1" Sch 40 steel pipe (not included) as needed for required length.