

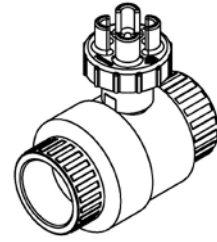

6400 Corporate Avenue  
Portage, MI 49002  
269-323-2495 or 800-374-0234  
Fax: 269-323-0630 or 866-879-5982  
www.colonialengineering.com

## SC Series Super C Compact Ball Valve



- SC Series valves are suitable for buried service. Use standard Champion sprinkler key with triangle handle, or Lasco plastic (VALVE KEY 1) wrench to operate (not included).
- Can also be used in standard service by manually turning the operating nut.
- Slo-Close operation with Patented gear-driven operating nut. Turn nut 360° clockwise, and ball will rotate 90° to close valve.
- Prevents shock from the sudden closure of a standard quarter turn ball valve.
- Replaces Gate Valves in irrigation piping systems, as well as other applications. Slo-Close valves are to be operated in the Open or Closed position. Do not attempt to meter or throttle in a partially open/closed position. Cycle time to open, 5-10 seconds. Cycle time to close, 3-5 seconds.

Climate conditions: PVC valves (and pipe & fittings) are pressure rated at 73 deg F, and must be de-rated as operating temperatures increase. Normally, we are referring to the fluid passing through the system, but in this case, we are also talking about the exterior environment. Once plastic pipe, valves and fittings are in a box and / or down hole, away from direct sunlight, they will be closer to ambient, so they can function at their rated pressure.

During construction, on a day with 85 deg F heat and direct-sun exposure, the surface temps of thermoplastic piping components may reach in excess of 140 deg F. PVC is fully de-rated for pressure at 140 deg, and can start to mal-form at 160 deg. So these components may be damaged and unusable after reaching this rate of heat.

The benefits of using a PVC Slo-Close valves (complete corrosion resistance and avoidance of water hammer, ease of installation) can be attained if the installing contractor takes care during construction to:

- Avoid storing them in direct sunlight or very hot areas.
- Avoid leaving them exposed to sunlight in open trenches
- Allow the valves, pipe and fittings to cool and settle before pressurizing them with water.
- Re-check the tightness of the union nuts prior to pressurizing the system.

These recommendations apply to any thermoplastic pipe, valves & fittings (PVC, or HDPE).

### OPERATION, INSTALLATION, & MAINTENANCE INSTRUCTIONS

**Operation:** Rotate handle slowly 360° clockwise to close, 360° counter-clockwise to open. Do not attempt to turn past the stops. Handle can be turned manually or by use of standard key wrench for direct buried service. Cycle time to open, 5-10 seconds. Cycle time to close, 3-5 seconds.

#### Installation:

PLEASE READ THE FOLLOWING INFORMATION PRIOR TO INSTALLING AND USING COLONIAL VALVE VALVES, STRAINERS, FILTERS, AND OTHER ASSOCIATED PRODUCTS. FAILURE TO FOLLOW THESE INSTRUCTIONS MAY RESULT IN SERIOUS INJURY.

1. Colonial Valve guarantees its products against defects in material and workmanship only. Colonial Valve assumes no responsibility for damage or injury resulting from improper installation, misapplication, or misuse of any product.
2. Colonial Valve assumes no responsibility for damage or injury resulting from chemical incompatibility between its products and the process fluids to which they are subjected. Compatibility charts provided in Colonial Valve literature are based on ambient temperatures of 70°F and are for reference only. Customer should always test to determine application correctness.
3. Consult Colonial Valve literature to determine operating pressure and temperature limitations before installing any Colonial Valve product. Note that the maximum recommended fluid velocity through any Colonial Valve product is eight feet per second. Higher flow rates can result in possible damage due to water hammer effect. Also note that maximum operating pressure is dependent upon material selection as well as operating temperature.
4. Colonial Valve products are designed primarily for use with non-compressible liquids. They should NEVER be used or tested with compressible fluids such as compressed air or gas.
5. Temperature effect on piping systems should always be considered when the systems are initially designed. Piping systems are required to be designed and supported to prevent excess mechanical loading on Colonial Valve equipment due to system misalignment, shock, vibration, weight, and the effects of thermal expansion and contraction.



6. Trench depth is also an important consideration in freezing climates. Installing the pipe deeper gives it more protection against frost. Where possible, all the pipe, valves and fittings should be installed below the soil frost line. Because PVC plastic products become brittle below 40°F, Colonial Valve recommends caution in their installation and use below this temperature.

**Note: Be sure that the valve is installed in the proper direction, per the Flow arrow indicated on the valve body.**

**SOCKET CONNECTION:**

Socket end connections are manufactured to ASTM D2467-94. Solvent cementing of socket end connections to pipe should be performed per ASTM specifications D2855-87. Cut pipe square. Chamfer and deburr pipe. Surfaces must be cleaned and free of moisture, oil, dirt and other foreign material. Apply primer to inside socket surface of end connection. Never allow primer or cement to contact valve ball or seat sealing surfaces, as leaking may result. Use a scrubbing motion. Repeat applications may be necessary to soften the surface of the socket. Next, liberally apply primer to the male end of the pipe to the length of the socket depth. Without delay, apply cement to the pipe while the surface is still wet with primer. Next apply cement lightly, but uniformly to the inside of the socket. Apply a second coat of cement to the pipe, and then join the valve socket to the pipe, rotating 1/4 turn in one direction as it is slipped to full depth of the socket. HOLD in this position for approx. 30 seconds to allow the connection to "set". After assembly wipe off excess cement. Full set time is a minimum of 30 minutes at 60 to 100° F.

**Maintenance:**

**The Super C Compact Valve is maintenance-free. It is permanently sealed at the factory.**

**Recommended Installation Layout**

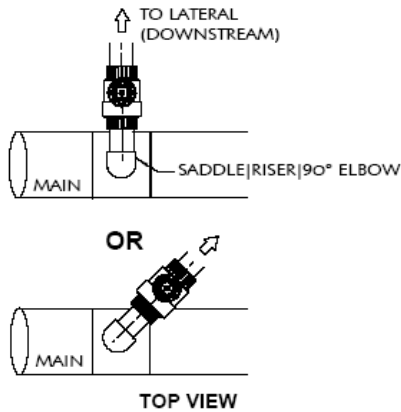

**Recommended Burial Depth**

