



### THE MOST VERSATILE AND COMPACT BRACKET AVAILABLE

The fiberglass-filled PVC mounting bracket fits securely on 1/2 through 2" Industrial Series, Full Block® True Union ball valves. This bracket is designed for the most demanding environments. It utilizes interlocking anti-torque locks, as well as nylon locking stainless steel fasteners to prevent loosening.

### FEATURES AND BENEFITS

- Compact size.
- Meets ISO 5211 standards.
- Compatible with many popular actuator brands.
- Cost effective — competitive with metal brackets.
- Corrosion resistant.
- Can be retrofitted without removing valve.
- Bracket material: glass filled PVC.
- Bolt composition: stainless steel.
- Available in sizes 1/2 through 2" for Full Block™ II True Union ball valves.
- Stem adapter sold separately.

### PVC MOUNTING BRACKETS

| Valve Size | Part Number |
|------------|-------------|
| 1/2"       | V07501A     |
| 3/4"       | V08501A     |
| 1"         | V10501A     |
| 1-1/4"     | V14501A     |
| 1-1/2"     | V17501A     |
| 2"         | V20501A     |

**NOTE:**  
See opposite side  
for brackets for  
3 & 4" valves.



## MOUNTING KIT FOR 1/2" - 2" VALVES

### VALVE ACTUATION BRACKET ASSEMBLY

#### ASSEMBLY DIAGRAM

1. Actuator
2. Stem adapter
3. Clamping bolts (2)
4. Mounting plate
5. Mounting plate bolts (4)
6. Upper bracket
7. Bracket bolts (2)
8. Valve
9. Lower bracket

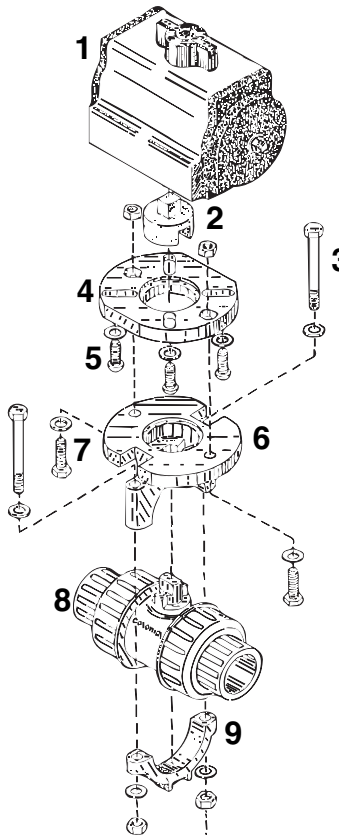

#### ASSEMBLY PROCEDURE

1. Insert nuts into mounting plate.
2. Bolt mounting plate to actuator.
3. Insert bolts into upper bracket.
4. Insert stem adapter into actuator.
5. Bolt upper bracket to mounting plate.
6. Insert valve stem into stem adapter slot through upper bracket.
7. Bolt bottom bracket to upper bracket.

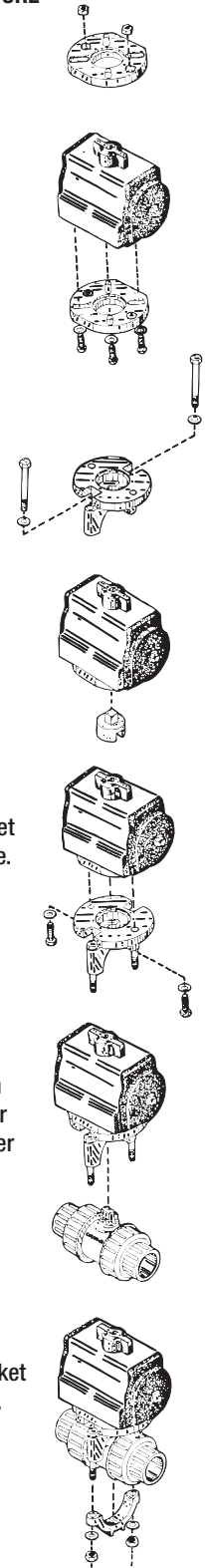

VALVE ACTUATION BRACKETS FOR INDUSTRIAL SERIES TRUE UNION BALL VALVES

Revised 12/14

**MOUNTING KIT FOR 1/2" – 2" VALVES (CONTINUED)**

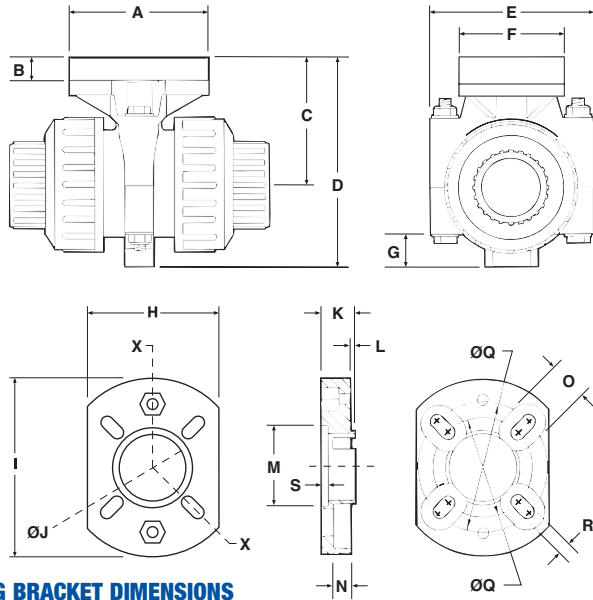

**MOUNTING BRACKET DIMENSIONS**

| SIZE   | A    | B    | C    | D    | E    | F    | G    | H    | I    | J    |
|--------|------|------|------|------|------|------|------|------|------|------|
| 1/2"   | 3.00 | .700 | 2.25 | 3.50 | 2.47 | 2.25 | .625 | 2.25 | 3.00 | 1.10 |
| 3/4"   | 3.00 | .600 | 2.50 | 4.00 | 3.19 | 2.25 | .688 | 2.25 | 3.00 | 1.10 |
| 1"     | 3.00 | .600 | 2.75 | 4.25 | 3.45 | 2.25 | .680 | 2.25 | 3.00 | 1.10 |
| 1-1/4" | 3.50 | .500 | 3.50 | 5.75 | 4.47 | 2.25 | 1.06 | 2.25 | 3.50 | 1.36 |
| 1-1/2" | 3.50 | .500 | 3.50 | 5.75 | 4.47 | 2.25 | 1.06 | 2.25 | 3.50 | 1.36 |
| 2"     | 3.50 | .500 | 4.50 | 7.38 | 5.75 | 2.25 | 1.45 | 2.25 | 3.50 | 1.36 |

**MOUNTING BRACKET DIMENSIONS**

| SIZE   | K    | L    | M    | N    | O    | P    | Q    | R    | S    | ISO 5211 |
|--------|------|------|------|------|------|------|------|------|------|----------|
| 1/2"   | .563 | .063 | 1.38 | .300 | .625 | 2.19 | 1.63 | .250 | .125 | F04      |
| 3/4"   | .563 | .063 | 1.38 | .300 | .625 | 2.19 | 1.63 | .250 | .125 | F04      |
| 1"     | .563 | .063 | 1.38 | .300 | .625 | 2.19 | 1.65 | .250 | .125 | F04      |
| 1-1/4" | .563 | .063 | —    | .250 | .625 | 2.19 | 1.97 | .250 | .125 | F05      |
| 1-1/2" | .563 | .063 | —    | .250 | .625 | 2.19 | 1.97 | .250 | .125 | F05      |
| 2"     | .563 | .063 | —    | .250 | .625 | 2.19 | 1.97 | .250 | .125 | F05      |

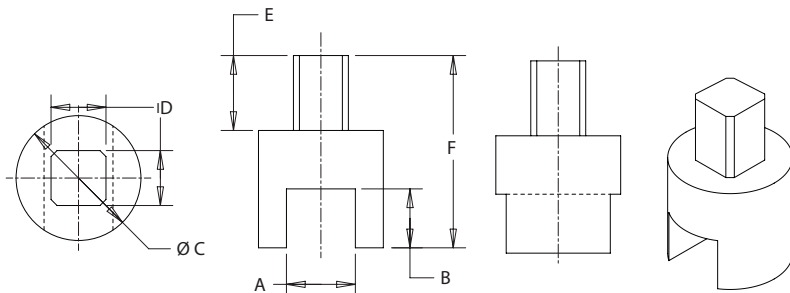

**MACHINED STEM COUPLING (SOLD SEPARATELY)**

| SIZE   | A    | B    | C    | D    | E    | F     | ISO | PART NUMBER |
|--------|------|------|------|------|------|-------|-----|-------------|
| 1/2"   | .320 | .335 | 1.00 | .430 | .500 | 1.440 | F04 | V07502A     |
| 3/4"   | .380 | .390 | 1.00 | .430 | .500 | 1.410 | F04 | V08502A     |
| 1"     | .440 | .450 | 1.00 | .430 | .500 | 1.490 | F04 | V10502A     |
| 1-1/2" | .560 | .570 | 1.25 | .550 | .629 | 1.740 | F05 | V17502A     |
| 1-1/4" | .560 | .570 | 1.25 | .430 | .500 | 1.490 | F04 | V17502A-F04 |
| 2"     | .690 | .575 | 1.25 | .550 | .629 | 1.920 | F05 | V20502A     |
| 2"     | .690 | .575 | 1.25 | .430 | .500 | 1.65  | F04 | V20502A-F04 |

**PVC PEDESTAL MOUNTING BRACKET FOR 3 & 4" FULL BLOCK® TRUE UNION BALL VALVES**



Constructed of PVC material, this bracket features a mounting pad with a PCD of 102mm (ISO 5211 F10), and a 17mm square stem coupling. The valve and mounting bracket are ordered separately, but will be shipped pre-assembled. The bracket is solvent-cemented to the valve at the factory, for a permanent, durable assembly.

The PVC mounting kit is suitable for use on both PVC and CPVC valves, providing that the atmospheric temperature (on the exterior of the valve) does not exceed 120 degrees. It is designed only for vertical installation (valve stem / actuator facing UP), not for horizontal (valve stem/actuator facing to the side) applications.

| Valve Size | Part Number |
|------------|-------------|
| 3"         | V30501P     |
| 4"         | V40501P     |

**TORQUE VALUES FOR TRUE UNION BALL VALVES**

| Valve Size | Opening Torque (In-Lbs) |
|------------|-------------------------|
| 1/2"       | 5                       |
| 3/4"       | 35                      |
| 1"         | 60                      |
| 1-1/4"     | 100                     |
| 1-1/2"     | 110                     |
| 2"         | 180                     |
| 2-1/2"     | 600                     |
| 3"         | 600                     |
| 4"         | 1,000                   |

**NOTE:**  
Mounting hardware not included. Requires (4) flat washers and bolts of 1.75" length.