

FEATURES AND BENEFITS

- Corrosion resistant thermoplastic body, disc and handle.
- Full boot seal for durable performance
- ANSI B16.5 Class 150 Flange Pattern
- 100% Bubble tight seal

SAMPLE ENGINEERING SPECIFICATIONS

Butterfly valves shall be gear actuated. Valve body and disc shall be produced of beige Polypropylene material. Valve boot/seal and O-rings shall be made of EPDM material. Shaft shall be made of stainless steel. The disc bore (center) shall contain a integrally molded stainless steel reinforcement square liner, which engages with the stainless steel valve shaft. Boot/seal (liner) and disc shall be the only wetted parts of the valve. Gear operator housing and handwheel shall be coated cast iron, with stainless steel fasteners and handwheel stem. Bolt pattern shall conform to ANSI/ASME B 16.5 Class 150 standard.



411NG Series
(See separate submittal
for this series.)

411NGP Series



REV 5/15/12

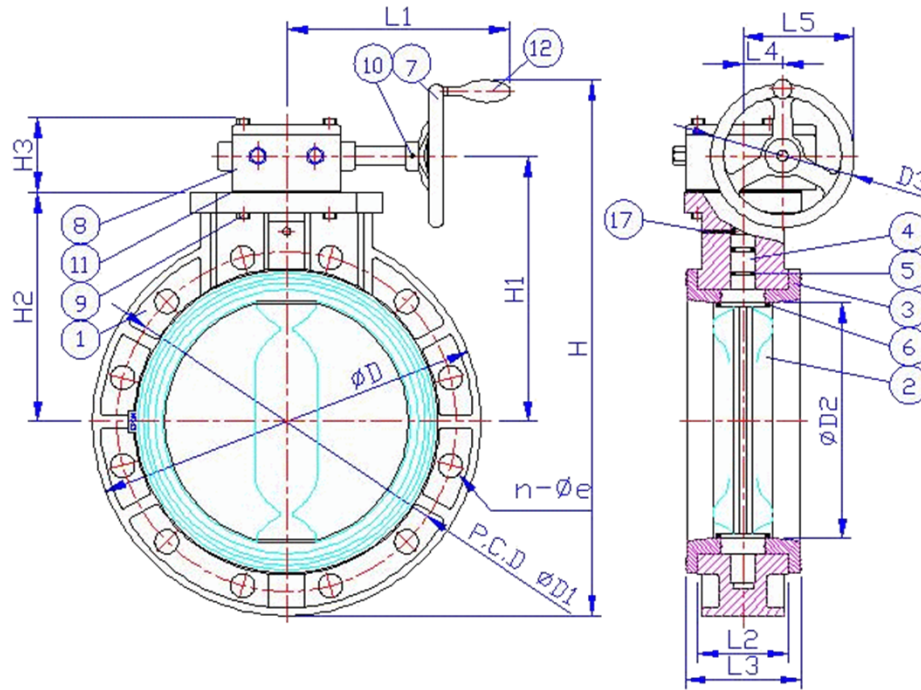

Temperature De-rating for Valves & Unions (Above 73° F)				
Temp (°F)	PVC	CPVC	PP	PVDF
73	1.00	1.00	1.00	1.00
80	.88	.96	.93	.93
90	.75	.92	.83	.87
100	.62	.85	.74	.82
110	.50	.77	.66	.76
120	.40	.70	.58	.71
130	.30	.62	.51	.65
140	.22	.55	.40	.61
150	NR	.47	.38	.57
160	NR	.40	.35	.54
170	NR	.32	.29	.51
180	NR	.25	.23	.47
200	NR	.18	.14	.41
210	NR	.15	.10	.38
240	NR	NR	NR	.28
280	NR	NR	NR	.22

NR: Not Recommended

Caution: Colonial recommends a minimum installation distance of 10 X the pipe diameter from a pump or other sources of turbulence.

SIZE	14"	16"	18"	20"	24"	
ANSI	ØD1	18.74	21.26	22.76	25.00	29.53
	n-Øe	12 - 1.14	16 - 1.14	16 - 1.26	20 - 1.26	20 - 1.38
	ØD	20.87	23.46	24.80	27.40	32.01
	ØD2	13.98	15.65	17.81	19.69	23.72
	ØD3	9.92	11.81	11.81	15.98	15.98
	H	28.86	34.25	35.83	40.83	45.91
	H1	13.46	16.54	17.52	19.13	21.89
	H2	11.81	13.58	14.57	16.14	18.90
	H3	3.07	4.72	4.61	5.63	5.63
	L1	12.99	13.90	13.90	15.35	15.35
	L2	4.45	5.98	6.42	6.77	7.64
	L3	5.00	6.54	7.05	7.44	8.23
	L4	2.36	3.19	3.19	4.72	4.72
	L5	7.28	9.09	9.09	12.72	12.72

NO.	PART	MATERIAL	QTY
1	BODY	Polypropylene	1
2	DISC	Polypropylene	1
3	SEAT SEAL	EPDM	1
4	STEM	SUS 410 Heat Treated	1
5	O-RING	EPDM	2
6	O-RING	EPDM	2
7	HANDWHEEL	FC20	1
8	GEAR BOX	CI POWDER PAINT	1
9	BOLT&WASHER	SUS 304	4
10	SPRING PIN	STEEL	1
11	PACKING	EPDM 6"-14"	1
12	SMALL HANDLE	STEEL	1
13	KEY	STEEL	1
14	SEAL	EPDM 14"-24"	2
15	METAL STAT	SUS 16"-24"	1
16	INSERT NUT	SUS 16"-24"	4-8
17	PIN	SUS	1

SIZE	14"	16"	18"	20"	24"
Part Number	V140411NGP	V160411NGP	V180411NGP	V200411NGP	V240411NGP
Pressure Rating*	100	86	72	51	51
Weight (lbs.)	101	152	167	268	353

*PSI at 73°F water non-shock